

NIPPON HELIUM INC.

Helium Center Plant

— Ideal Helium Plant “Reduce losses to the minimum” —



Center Plant Overview

Outline

- **Location** Kawasaki City, Kanagawa Pref.
- **Floor Space** 2,300m² (Site area 6,616m²)
- **Productivity** 300Nm³/h
- **Products**
 - Helium Products
 - Helium (4N, 99.997%)
 - High-Purity Helium (5N, 99.999%)
 - Ultra High-Purity Helium (6N, 99.9999%)
 - Liquefied Helium
 - Mixture Gas
 - He+Ar, He+N₂, He+O₂
 - He+N₂+CO₂, other (Order made)
 - Rare Gas
 - Neon, Krypton, Xenon

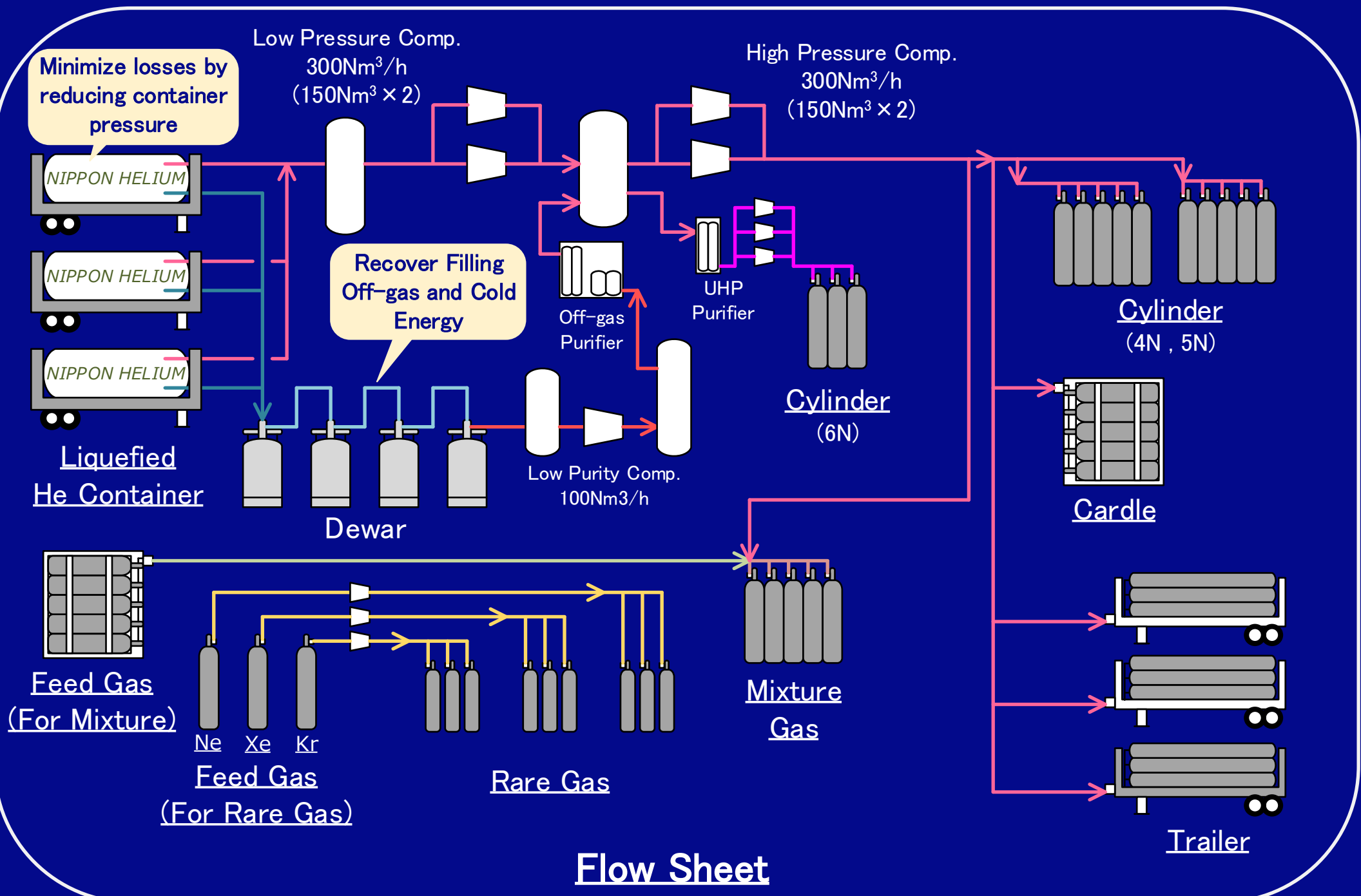

Flow Sheet